

**DWG. NO.**  
A503-75x75-Facta

**DWG REF**

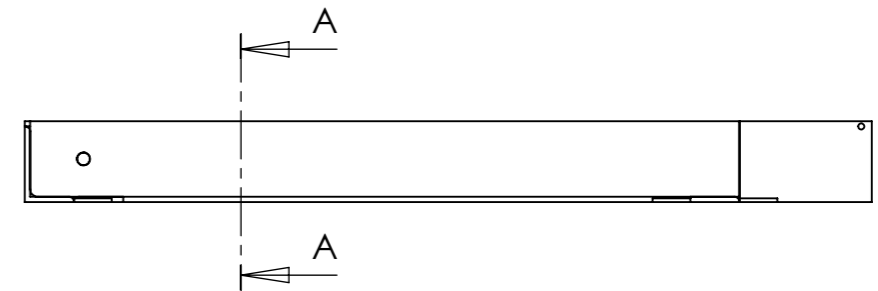
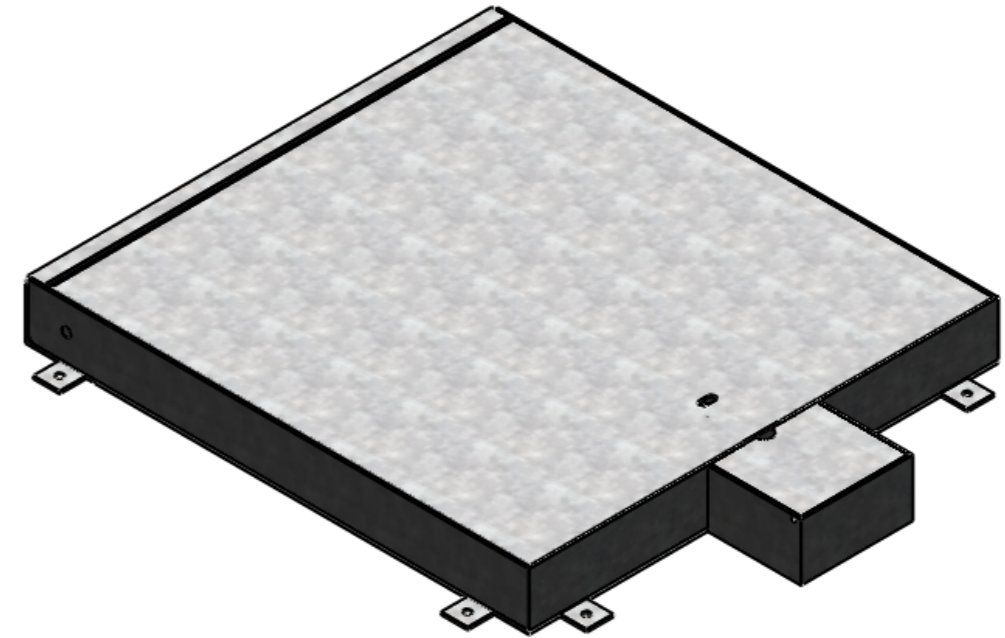

Unit 3 Power Park, Towers Business Park, Rugeley, Staffs. WS15 1UZ  
Telephone 01889 572620 Fax 01889 572629  
Email sales@aquacastltd.com

Customer:



**A3**

Description: 750x750 Torsion Spring C&F Facta

	Name	Date	Material:	Mild Steel
Drawn By:	Sandy Mcfie-Hyland	26/10/2009	Finish:	Galvanised Steel
Checked By:	Steve Hulse	26/10/2009	Loading:	Facta
Scale:	1:10		Weight(kg):	89.88