

DWG. NO.

A073-120x90-Facta

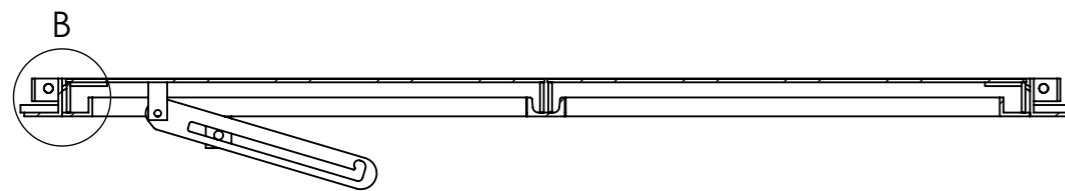

SECTION A-A

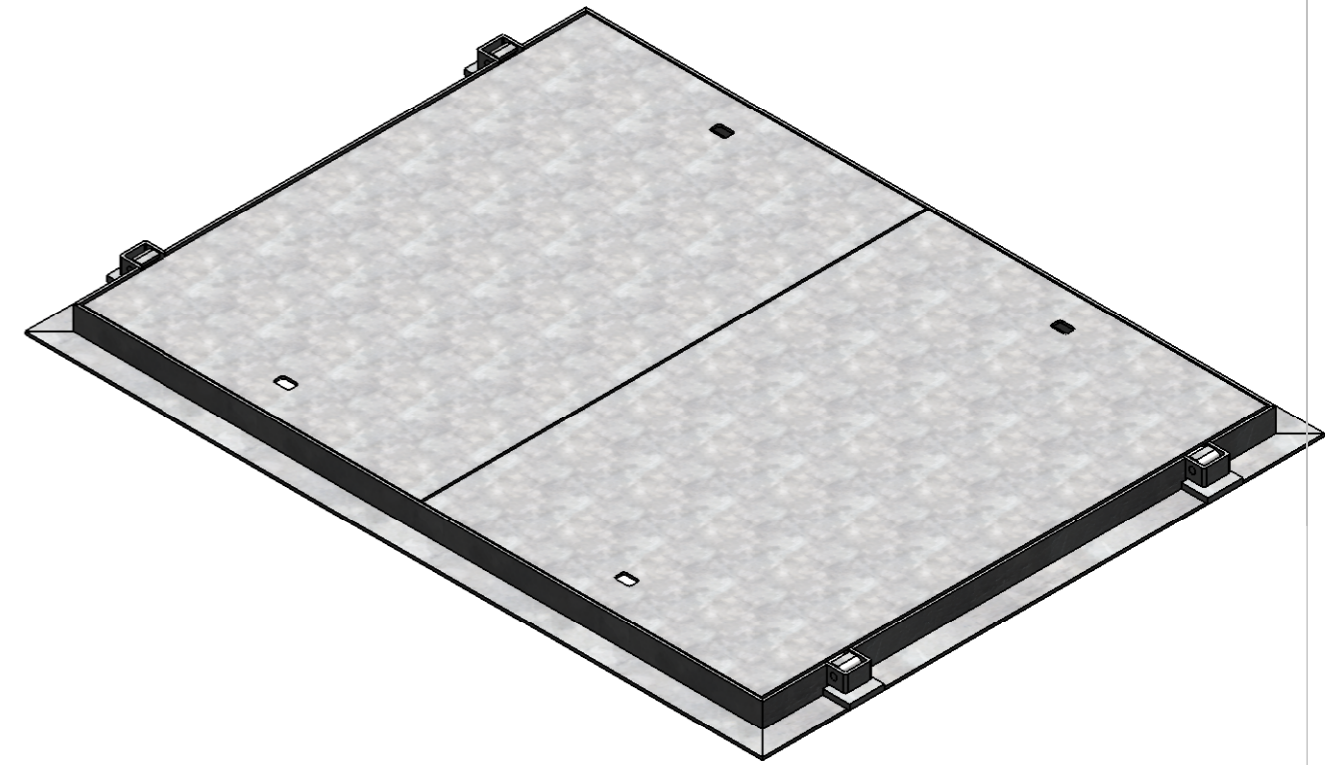
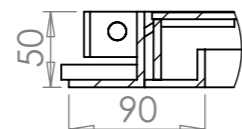

DETAIL B
SCALE 1 : 5

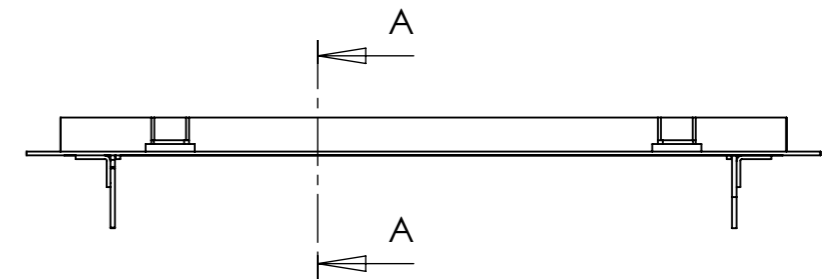

Unit 3 Power Park, Towers Business Park, Rugeley, Staffs. WS15 1UZ
Telephone 01889 572620 Fax 01889 572629
Email sales@aquacastltd.com

Customer:



A3

Description: 1200x900 Twin Hinged C&F

	Name	Date	Material:	Mild Steel
Drawn By:	Sandy Mcfie-Hyland	11/05/2009	Finish:	Galvanised Steel
Checked By:	Steve Hulse	11/05/2009	Loading:	Facta
Scale:	1:10		Weight(kg):	91.54